

STANDARD AIR KIT DOC.....

WWW.X2INDUSTRIES.COM

Front to back much of the difference between our air suspension systems are in the air management equipment, the process between our air ride system installation techniques are very similar.

VALVE PLUMBING OPTIONS:

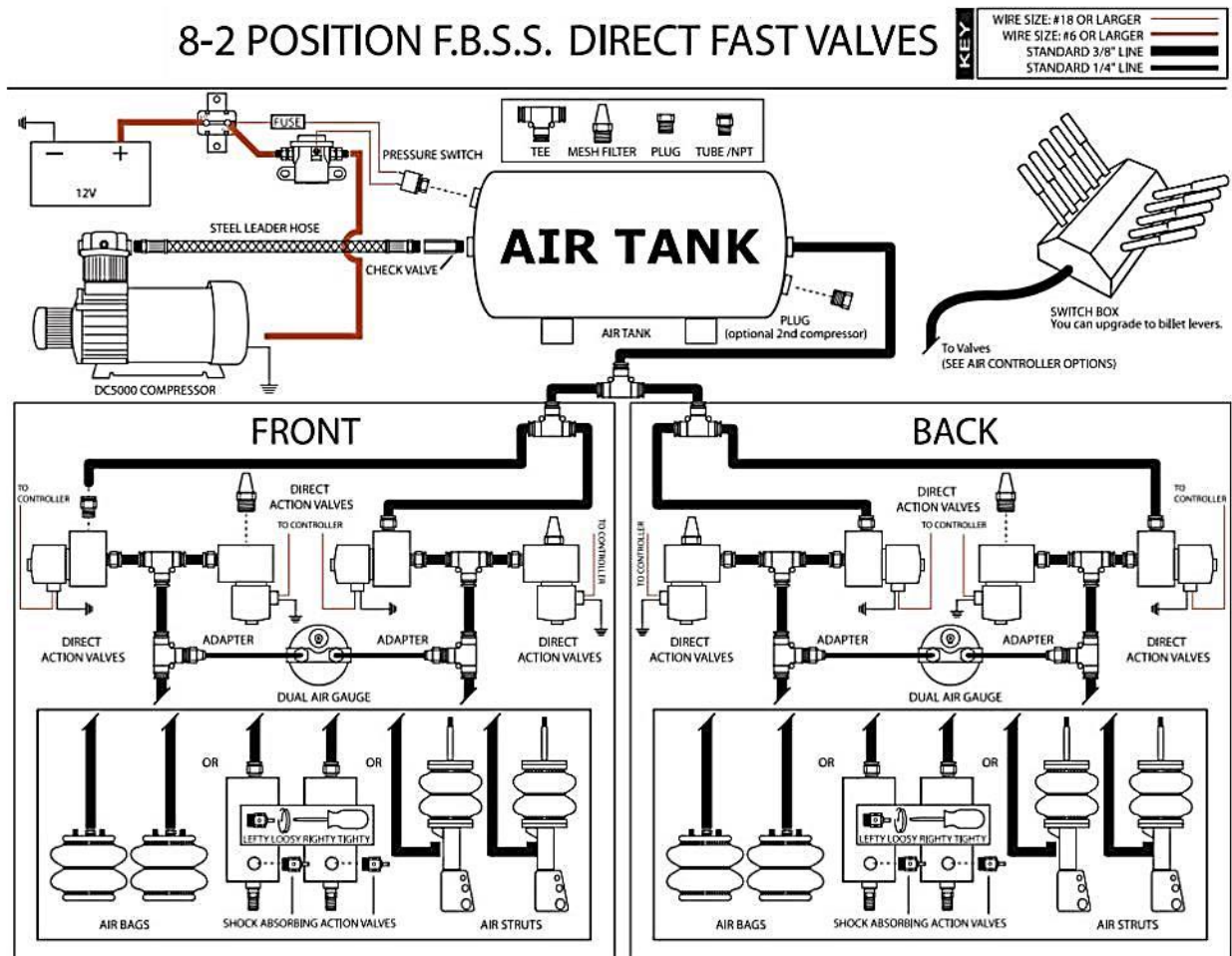

Previous Standard Systems used a few t-fittings to accomplish what the below configuration does with much less plumbing and airline.

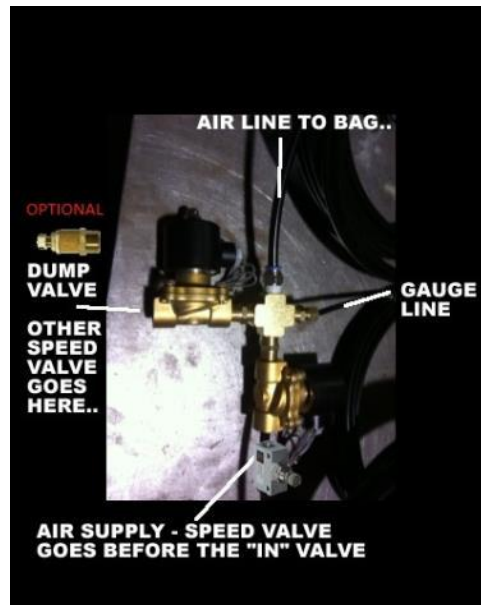

Air suspension utilizes 2 valves for fill and dump, per corner. Your 8 individual valves will work in sets of 2 for 4 wheels. The above illustration shows the installation of the valves on the 4 side mounted port 3 gallon air tank.

COMPRESSOR WIRING AND PLUMBING:

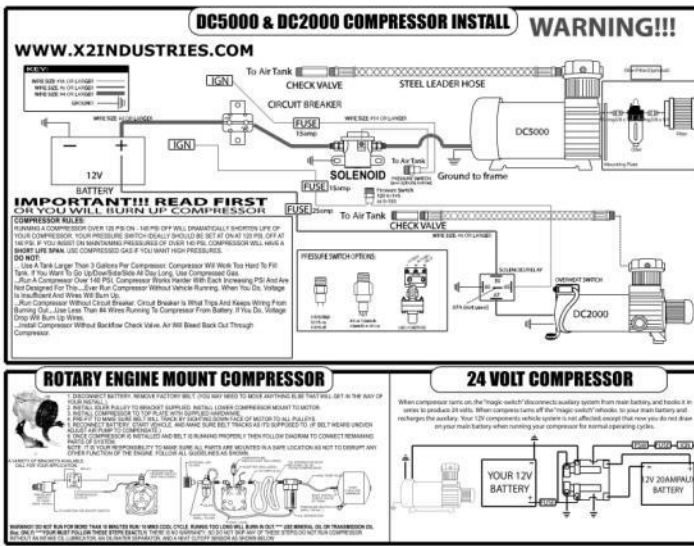

RELAY WIRING FOR COMPRESSOR INSTALL

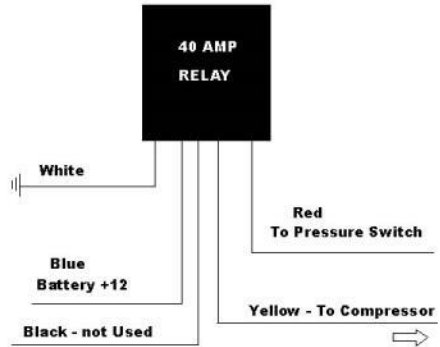

Typical Compressor Installation diagram

(click on compressor to purchase)

YOU MUST INSTALL A CHECK VALVE ONTO YOUR TANK TO PREVENT COMPRESSOR FROM BURNING UP.

MUST USE A MINIMUM OF 4 GAUGE WIRE ON DC07 COMPRESSOR.

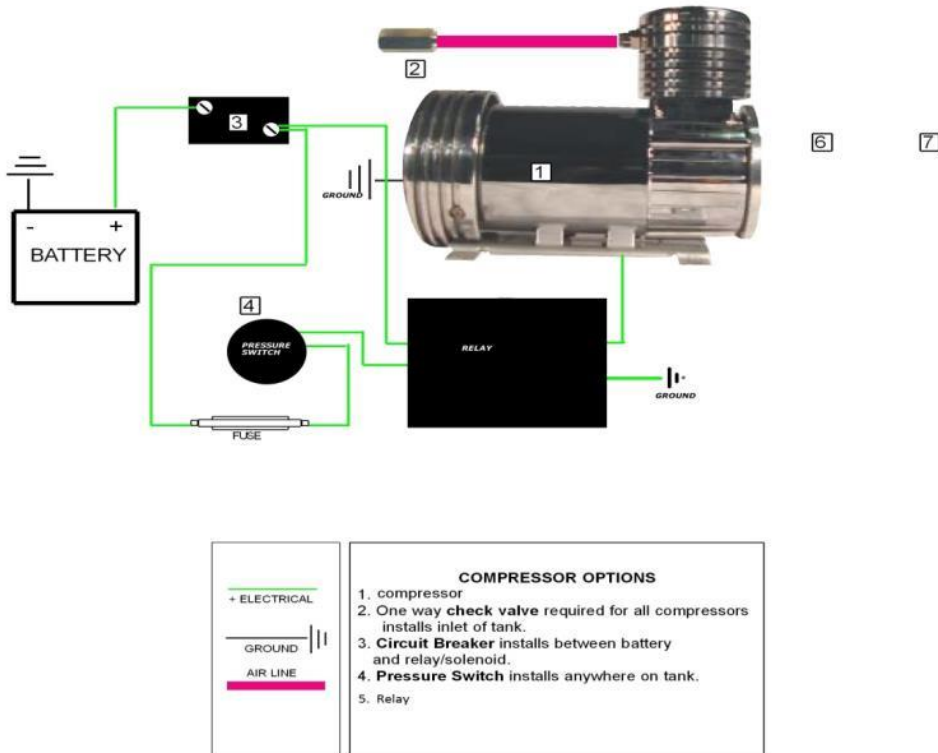

COMP GEN SETUP.PDF

DIAGRAM #6

AIRBAG/BRACKETS for all trucks & some cars

Electric "gold" 2-position valves Installation diagram

(click on each image to purchase individual parts)

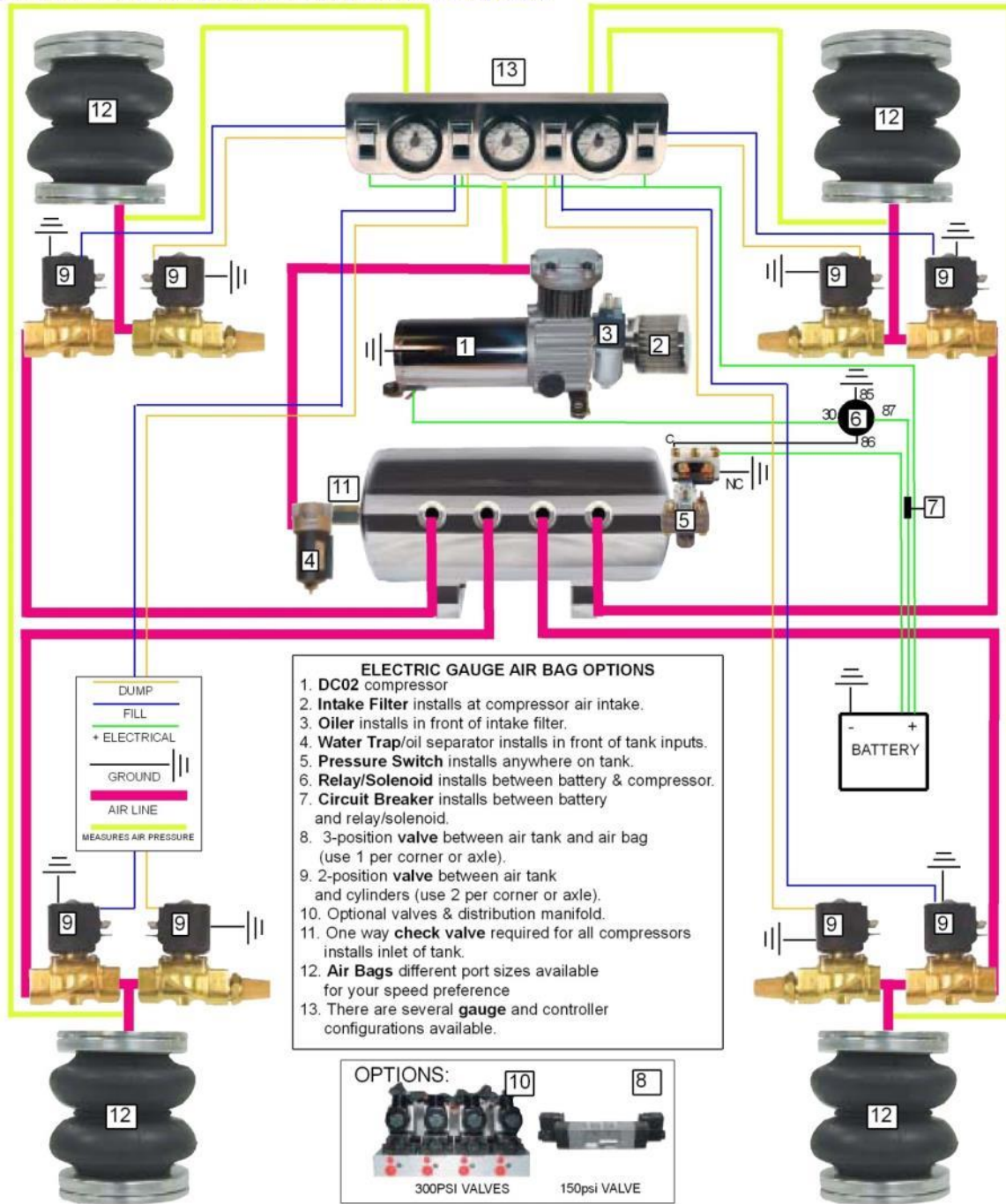

AIR KIT GLDVALV AIR BAG.PDF

DIAGRAM #3

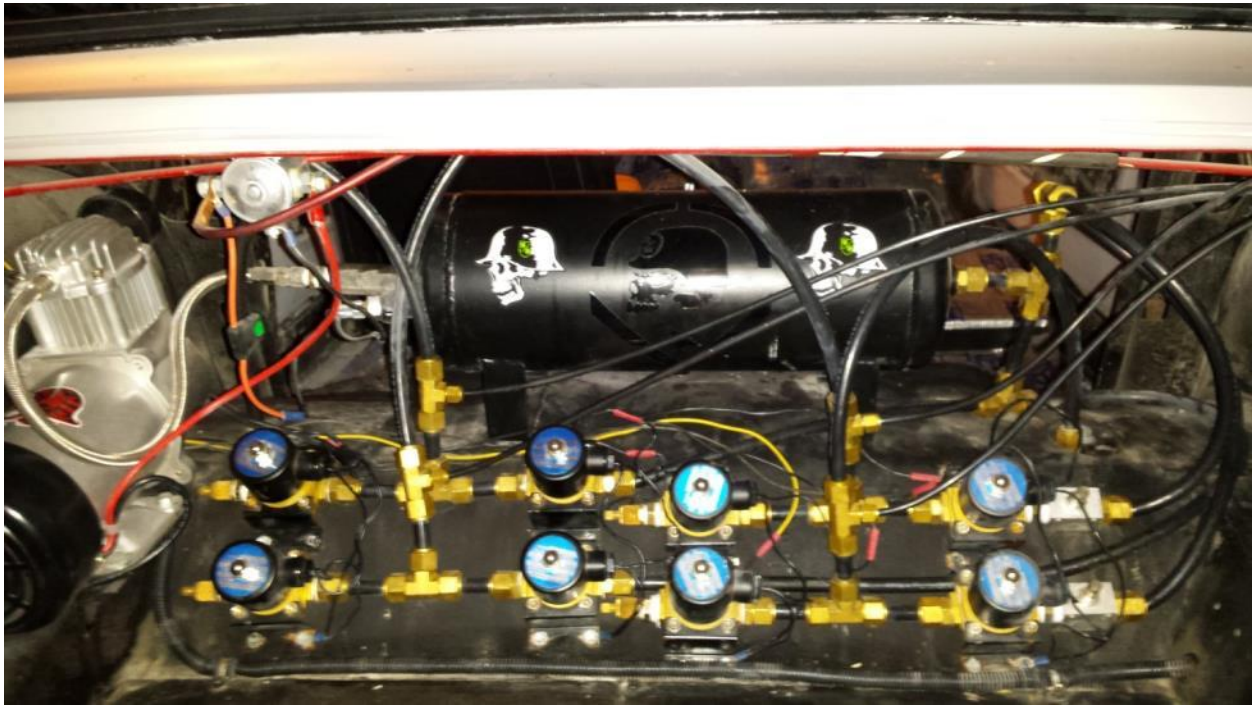

When installing your compressor you will need an amp kit minus the RCA's from the kit for the power to your system.

Parts needed when wiring up your compressor are "relay", "pressure switch", "main 12 volt power lead", "ground" and a thinner "remote trigger power wire"

Diagram number six above gives you a general idea of how these parts will work in unison to provide your system with maintained air pressure.

The steel braded airline that connects from your compressor to your tank has a larger end which will be at the tank side, this larger end houses a check valve to ensure the air does not leak from the tank back into the compressor and out.

GAUGE PANEL TO VALVE WIRING:

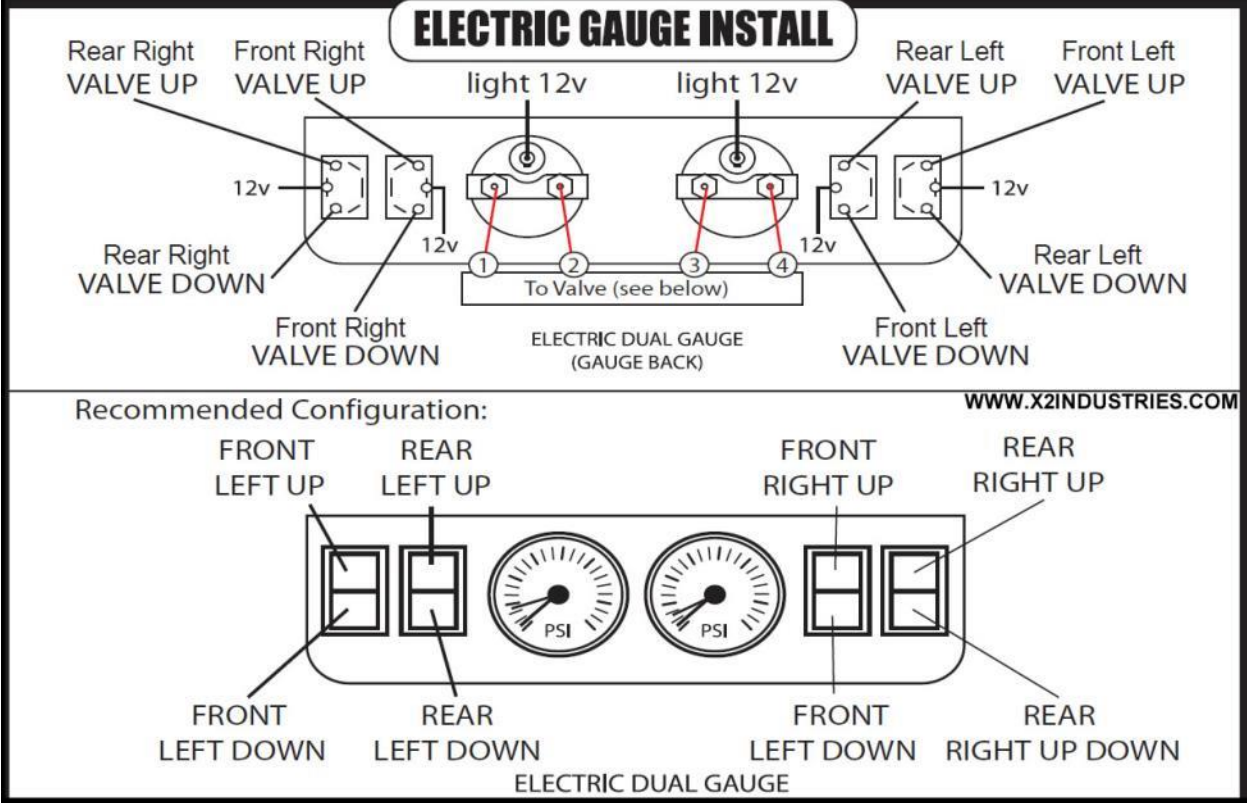

REAR CHASSIS COMPONENTS:

Typical Weld-On 4-Link Installation Instructions

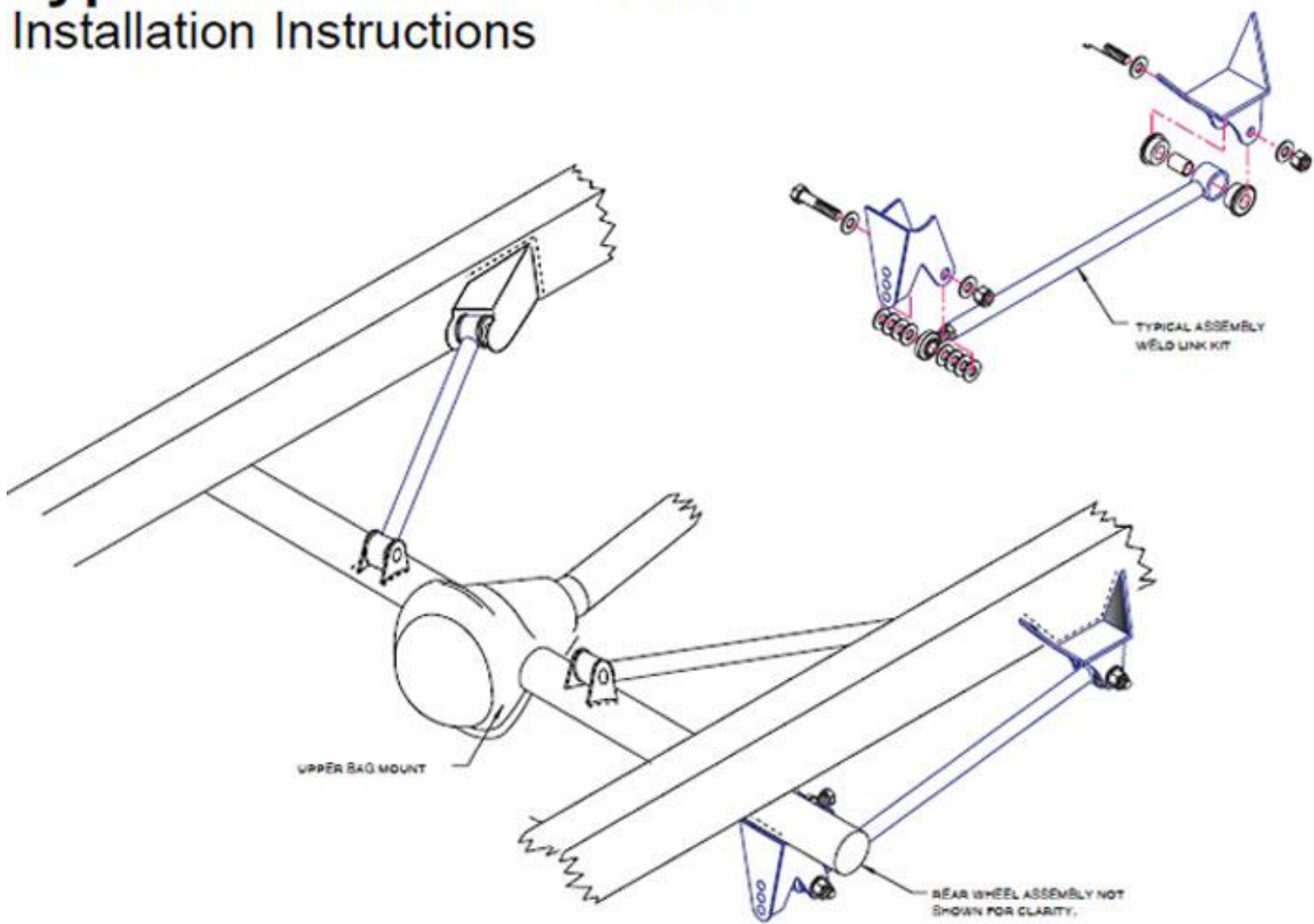

www.x2industries.com

Typical Weld-On 4-Link Installation Instructions

(Click on picture of part to purchase.)

1. FIGURE 1-1 SHOW YOU A COMPLETELY ASSEMBLED 4 LINK ASSEMBLY. IT IS SHOWN WITH RECOMMENDED AIR BAGS, YOU MAY USE AIR SHOCKS OR COIL OVER SHOCKS. BUT THIS HARDWARE IS NOT INCLUDED AND MUST BE PURCHASED SEPARATELY.

2. MAKE SURE THAT THE VEHICLE IS ON LEVEL GROUND AND THE FRAME IS PLACED ON JACK STANDS. NEVER WORK ON A VEHICLE THAT IS SITTING ON JACKS.

3. ONCE THE VEHICLE IS SECURE REMOVE YOUR REAR TIRE, STOCK SHOCKS, UNBOLT YOUR LEAF SPRINGS, HANGERS AND REMOVE.

4. SEE FIGURE 1-2 THIS FIGURE SHOWS YOUR AIR BAG ASSEMBLY TO YOUR LOWER AND UPPER BAG MOUNTS. NOTE: YOUR LOWER BAG MOUNT WELDS TO THE BOTTOM OF YOUR AXLE OR IT MAY BE FLIPPED OVER AND WELDED TO THE TOP OF YOUR AXLE DEPENDING ON YOUR HEIGHT NEEDS. YOUR UPPER BAG MOUNT MUST BE CUT FROM EACH END TO FIT YOUR FRAME. ONCE THIS IS DONE ALIGN YOUR UPPER BAG MOUNT WITH YOUR LOWER BAG MOUNT AND WELD IN PLACE. BE SURE THAT YOUR AIR BAG IS REMOVED AND THAT YOUR AXLE IS CENTERED BEFORE WELDING ANYTHING.

5. SEE FIGURE 1-3 THIS FIGURE SHOWS YOUR 4 LINKS BAR INSTALLATION TO YOUR FRONT AND AXLE MOUNTS. FRONT BRACKETS CAN BE PLACED INSIDE OR ON THE OUTSIDE OF YOUR FRAME. DEPENDING ON YOUR OWN CLEARANCE ISSUES. THEY MUST BE WELDED FLUSH WITH THE BOTTOM OF YOUR FRAME RAIL. SEE FIGURE 1-1 AND 1-3, THESE BOTH SHOW THEM INSTALLED ON THE SIDE OF YOUR FRAME

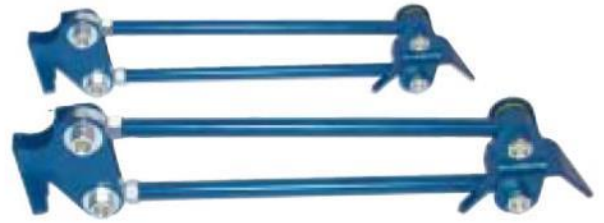

6. AXLE BRACKETS ARE TO BE PLACED PARALLEL AND EQUAL DISTANCES FROM THE AXLE ENDS. BE SURE THAT YOUR AXLE IS CENTERED AND THAT YOUR 4 LINK BARS ARE PARALLEL BEFORE WELDING INTO PLACE.

7. INSTALL BOTH YOUR UPPER AND LOWER 4 LINK BARS. THE LINKS ARE ADJUSTABLE , INSTALL THE ADJUSTABLE END TOWARDS THE REAR OF THE TRUCK. YOUR 5/8 WASHERS ARE USED AS SHIMS ON THE ADJUSTABLE ENDS. SEE FIGURE 1-3 FOR ASSEMBLY.

8. BOLT TOGETHER AND SET TRUCK AT DRIVE HEIGHT. NOW YOU SHOULD BE READY TO WELD YOUR NEW PANHARD BAR FROM THE SIDE OF THE OF THE FRAME TO YOUR DIFFERENTIAL. THE BAR SHOULD RUN PARALLEL TO YOUR AXLE AND INSTALLED SO IT DOES NOT COME IN CONTACT WITH ANYTHING. THE PURPOSE OF THIS BAR IS TO PROVIDE LATERAL SUPPORT TO YOUR VEHICLE. MEANING KEEPING THE AXLE FROM SHIFTING FROM SIDE TO SIDE. BE SURE THAT YOUR AXLE IS CENTERED BEFORE WELDING YOUR BAR. FIGURE 1-4 SHOWS YOUR PAN HARD BAR WELDED IN PLACE.

9. IF USING AIR BAGS BE SURE THAT THEY ARE REMOVED BEFORE WELDING ANYTHING AND THAT THEY HAVE THE APPROPRIATE CLEARANCES. AIR BAGS MUST NOT COME IN CONTACT WITH ANYTHING!!!! (YOU AS THE CONSUMER ARE RESPONSIBLE FOR YOUR AIR BAGS. WE DO NOT WARRANTY BAGS.)

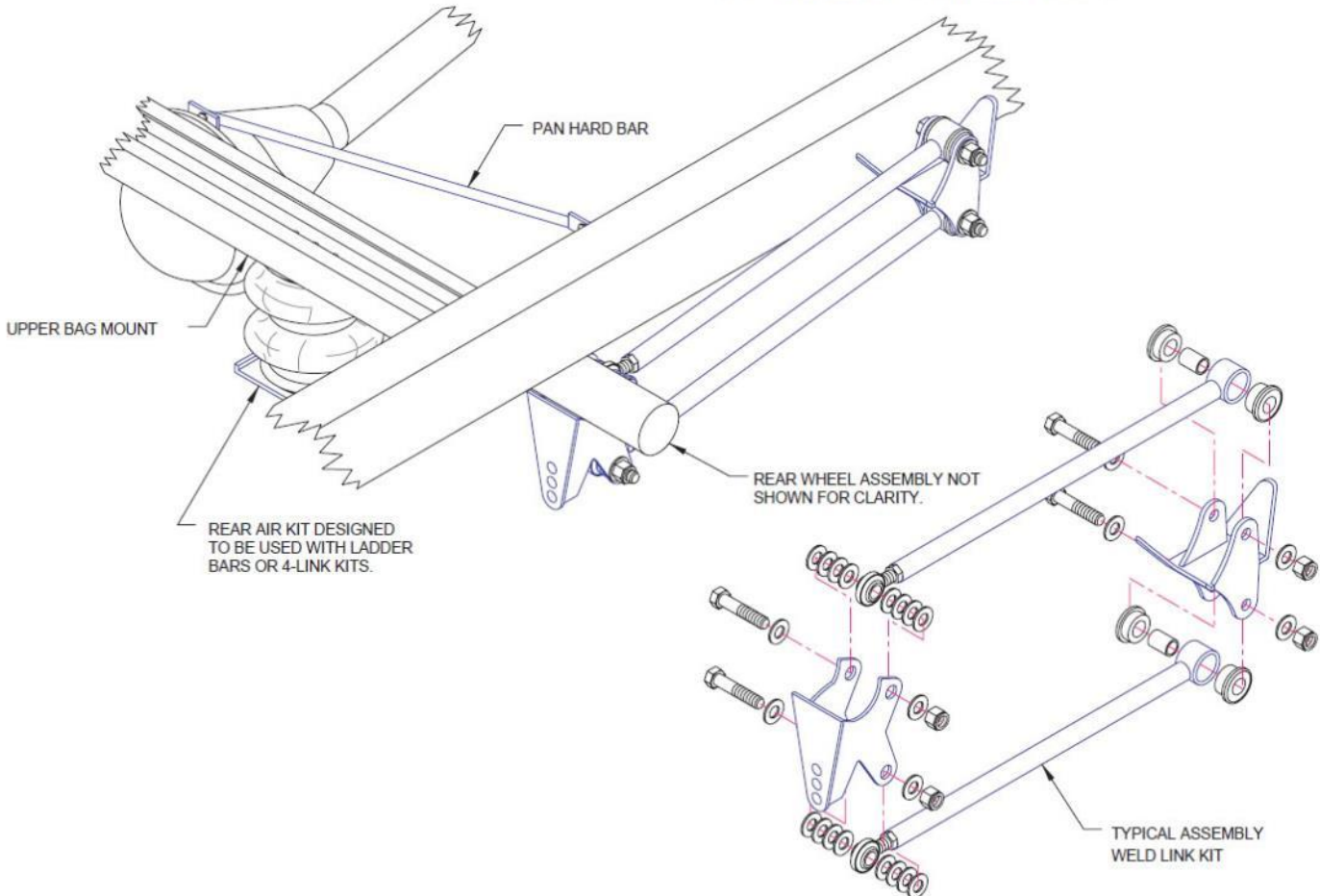





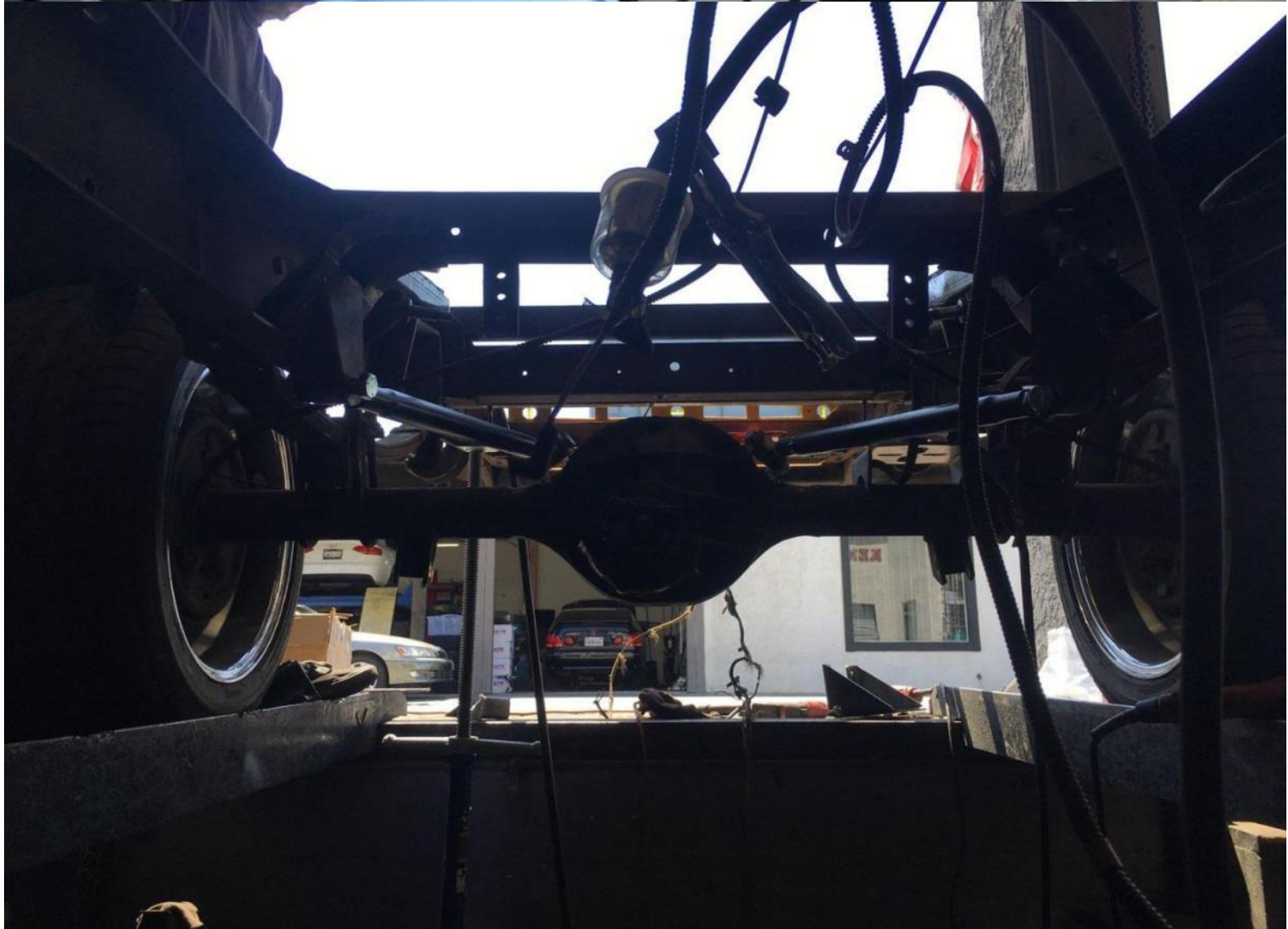







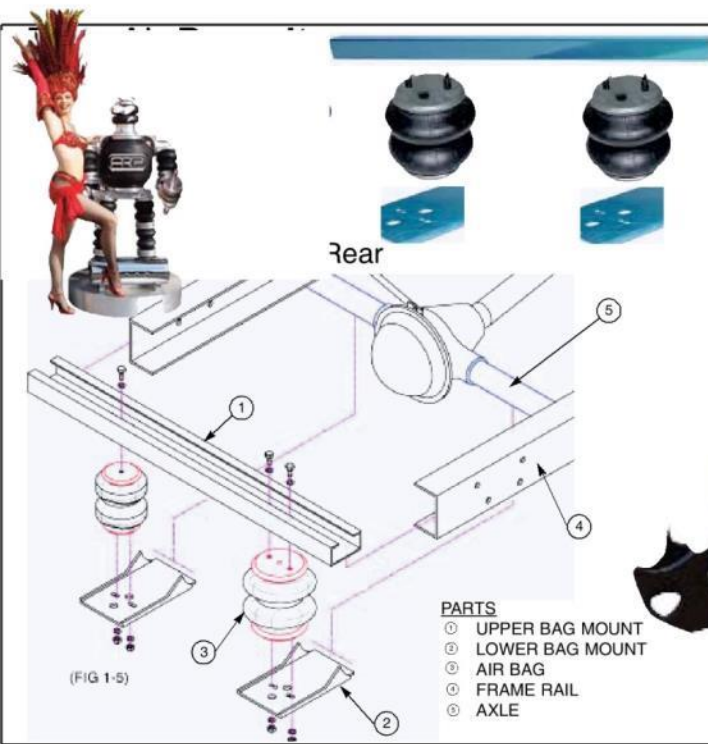

Typical Rear for cars/trucks with Leaf Springs

Lower bag mounts are welded to the bottom of your axle, or they may be flipped over and welded to the top of the axle, depending on your intended ride height.

Cross Member must be trimmed equally on both ends to fit inside your frame.

Align the lower bag mount to the top cross-member holes before welding in place. Be sure you have a certified welder so you do not burn thru your axle housing.

MEASURE TWICE, cut and weld only once!

Deep Drop brackets can be specified. They position the bag approx 4" below the axle for those that want to be lower.



Truck Over Axle

9" Rolling Lobe Option

Typical Car w/coils

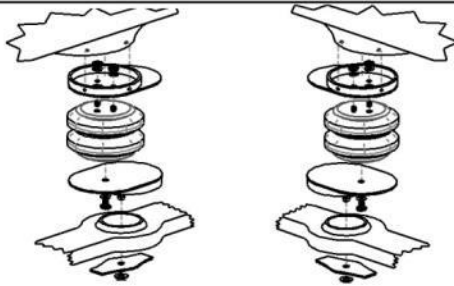

Typical Rear for cars/trucks with Coilsprings

Remove or trim/modify bumpstops as necessary

Brackets we sometimes send extra top brackets so you can choose a higher or lower airbag position. The shorter the bracket, the lower you go. Remember, if you have to put too much air in the bag to get to ride height, you may ride rough. find the "SweetSpot"

MEASURE TWICE, cut and weld only once!

Triangulated Weldon 4-Link

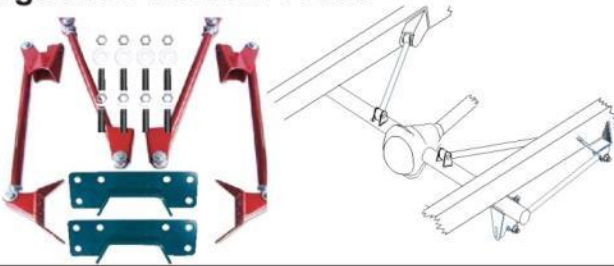

Refer to rear airbag mounting directions at top of page.

MEASURE TWICE, cut and weld only once!

With leafsprings still on vehicle, set desired "ride height". (where vehicle will be driven most) use sandbags, or weight the trunk down. Make sure pinion angle is correct.

With leafs still intact, align upper link bars at as wide of an angle from center as possible. (no less than 15 degrees each side. Use axle tabs at axle and angled frame bracket at frame rail. boxing frame is ideal, but not required.

Remove leaf pack from one side of vehicle. Support axle and vehicle so you do not disturb position of axle and pinion angle of drive shaft.

Position lower links with frame hanger bracket at frame rail and lower axle bracket at axle.

Upper and Lower links should be at same horizontal angle and spaced evenly at frame and axle to keep proper **geometry** and pinion angle through travel of rear end.

Repeat on opposite side.

***Relocation of gas tank and other factory components may be required.**

*** All weld contact points should be ground clean and welded by a certified welder. (this will be holding your rear end in place)**

*** Check/double check clearances binding throughout travel**

*****These are just suggestions, there are many ways to do this. If installing a Bolt-on 4link, do one side at a time.**

Parallel Weldon 4-Link with Panhard Bar

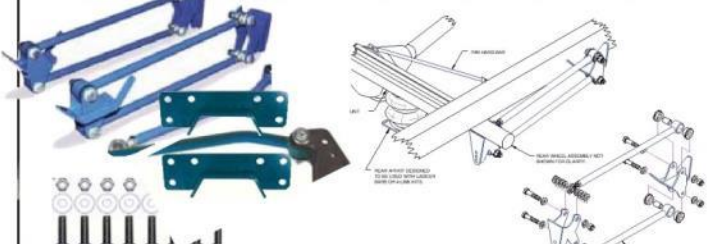

Bolt-on 4-Link/Panhard Bar

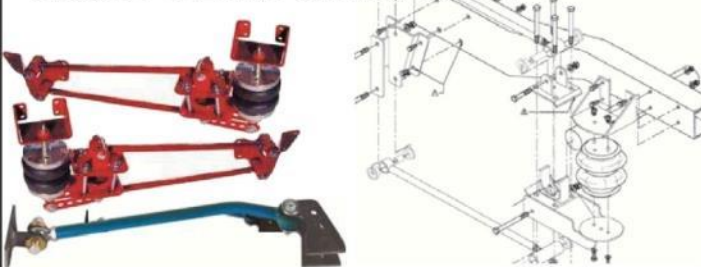

FRONT CHASSIS COMPONENTS:

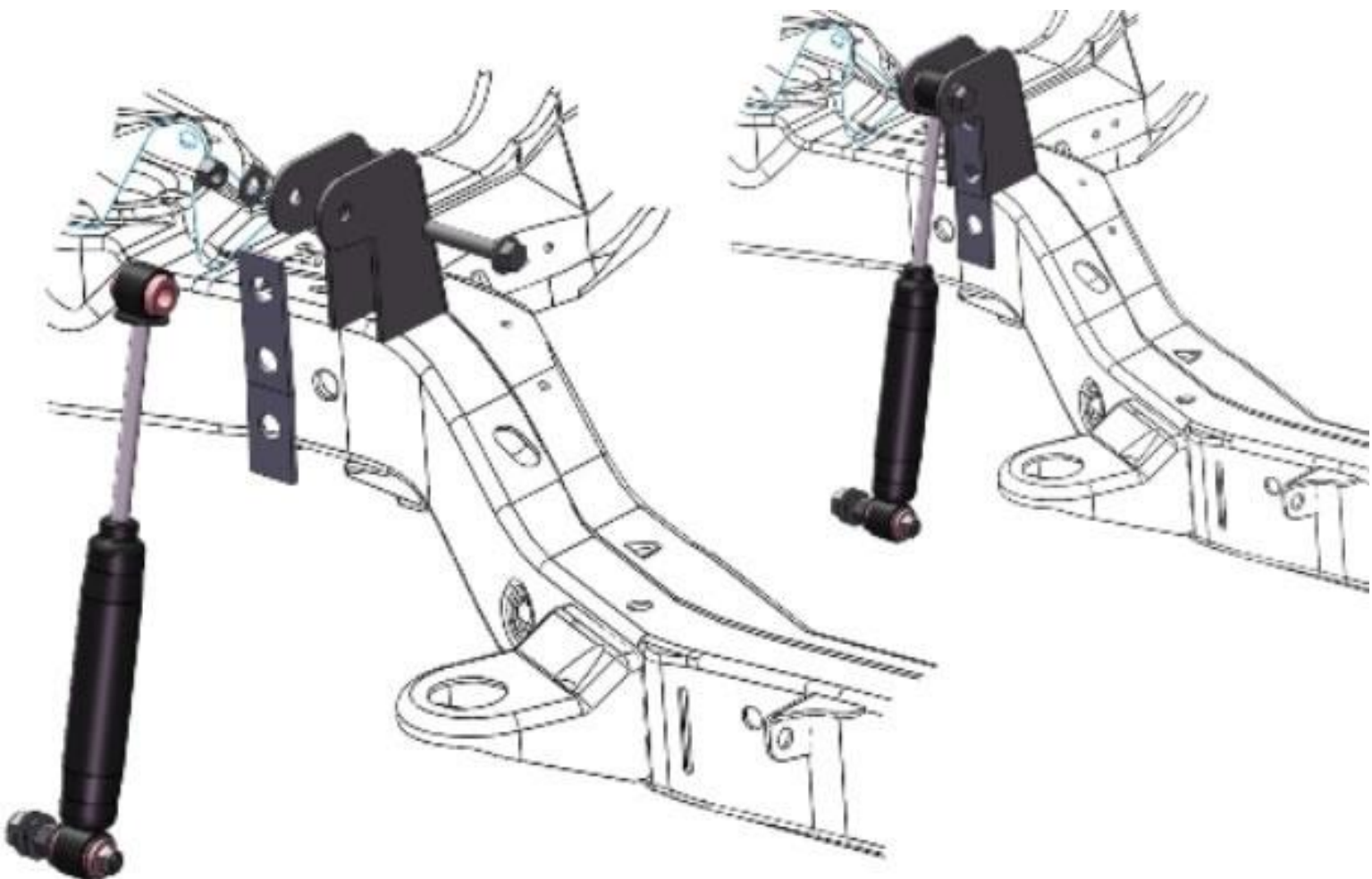

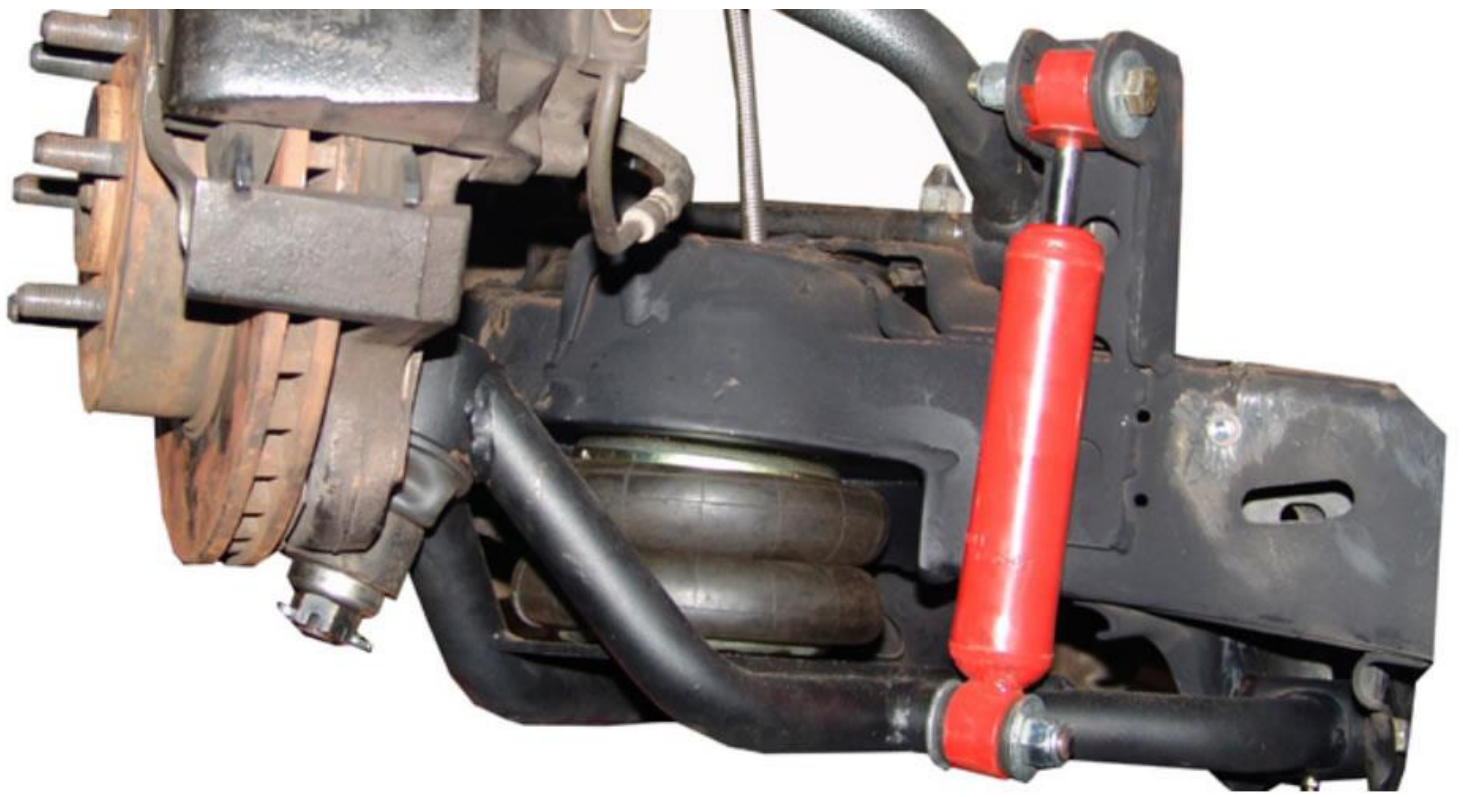

Shock Relocator Instructions

1. Before installing shock relocator kit, make sure the air suspension components are installed and operational.
2. Jack vehicle up and support at frame rails to permit articulation of suspension.
3. Remove wheels.
4. Determine whether the steering linkage runs along the front or backside of the control arm. The shock relocator will be installed on the opposite side of arm as the steering.
5. Using floor jack, raise lower control arm until suspension is fully compressed.
6. Position shock next to control arm in area to be mounted as close to frame as possible and move lower mount out towards spindle 3". Mark lower control arm and drill hole and bolt or weld lower stud in place.
7. With suspension still fully compressed bolt upper bracket to shock and bolt shock to lower mount.
8. Position upper bracket on top of frame rail. Measure distance between the upper and lower bolts center to center.
9. Using this measurement to shorten the upper mount removing excess material from bottom to achieve a 10" measurement bolt to bolt with upper bracket positioned on top of the frame where it will be mounted.
10. Tack weld upper bracket in place.
11. Cycle suspension up and down to check for proper travel, binding and clearance.
12. Remove shock.
13. Using upper mount as a reference cut the long side of reinforcement strap to match the length of newly shortened upper mount.
14. Use reinforcement strap to close off front opening of upper mount with the lower part of the reinforcement strap running down the side of the frame rail. Weld in place.
15. Complete welding of upper mount where only tack welds used before to completely join upper mount to frame.
16. Paint all raw components to prevent rust..

Shock Relocator Parts List

- 2- Upper shock mounts
- 2- Lower shock studs
- 2- Upper mount reinforcement straps
- 2- 1300LL shocks

Hardware List

- 2- 1/2-13 x 2-3/4 bolts
- 2- 1/2-13 crimp nuts

Cars & Trucks with Upper & Lower Control Arm

You will need to purchase a shock relocater kit. Brackets must be tack welded with the shock extended, and permanently welded after checking travel.

Remove, or modify bump stops as necessary. Do whatever it takes to ensure bag does not contact metal.

Temporarily tack-weld bottom plate to determine proper position on Lower Control Arm

Bolt top plate to airbag, rotate for position as necessary

Before permanently welding into position, make sure your shock travel and airbag has complete travel without touching other components. Abrasions or cuts from body contact are not covered by warranty.

MEASURE TWICE, cut and weld only once!

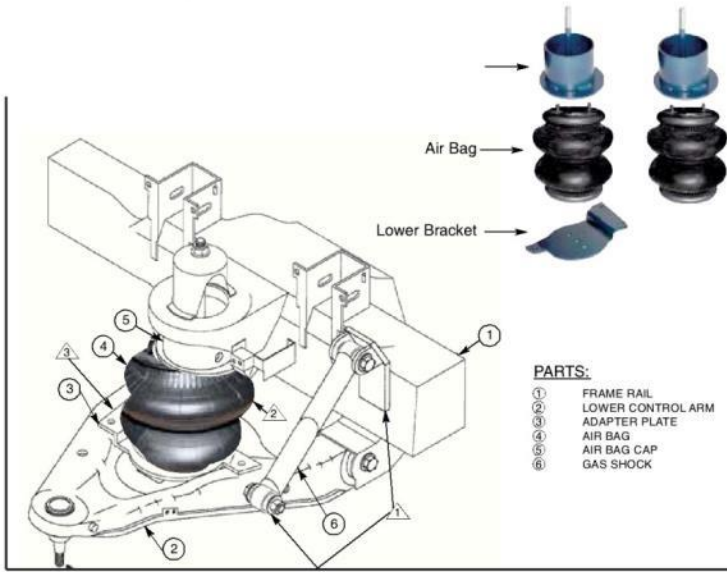

Most Mini Trucks

Any obstructions such as brake lines or shock towers must be removed to allow the new brackets to be installed. Weld reinforcement gussets as necessary to strengthen frames/supports.

Remove or loosen torsion bars

You will need to purchase a shock relocater kit. Brackets must be tack welded with the shock extended, and permanently welded after checking travel.

Remove, or modify bump stops as necessary. Do whatever it takes to ensure bag does not contact metal.

Temporarily tack-weld bottom plate to determine proper position on Lower Control Arm

Bolt top plate to airbag, rotate for position as necessary

Before permanently welding into position, make sure your shock travel and airbag has complete travel without touching other components. Abrasions or cuts from body contact are not covered by warranty.

MEASURE TWICE, cut and weld only once!

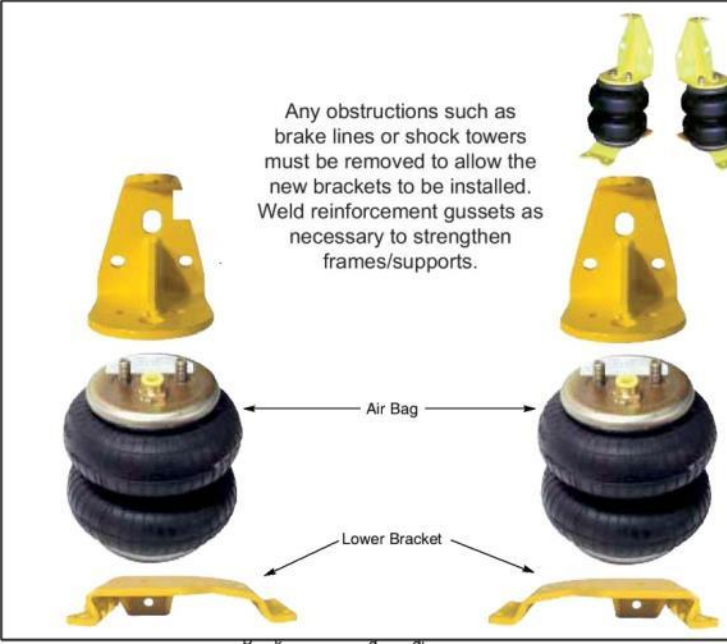

Ford Trucks & Vans with I-Beams *WELDON KIT

This kit is for use with FACTORY BEAMS, if you have had lower I-Beams installed, you will have to use the optional lowered barrels.

You will need to purchase a shock relocater kit. Brackets must be tack welded with the shock extended, and permanently welded after checking travel.

The drivers side is curved and must be cut with a diegrinder. Remove just enough to fit new brackets snugly in place. Tack-weld or bolt temporarily in place. When you are SURE of position, have a certified welder apply finished welds.

Make sure bags/brackets are straight up/down in relation to upper brackets and perch bolt when at drive height. Do not use existing holes as a guide. Radius arms can be adjusted up to 1/2" if necessary. Abrasions or cuts from body contact are not covered by warranty.

MEASURE TWICE, cut and weld only once!

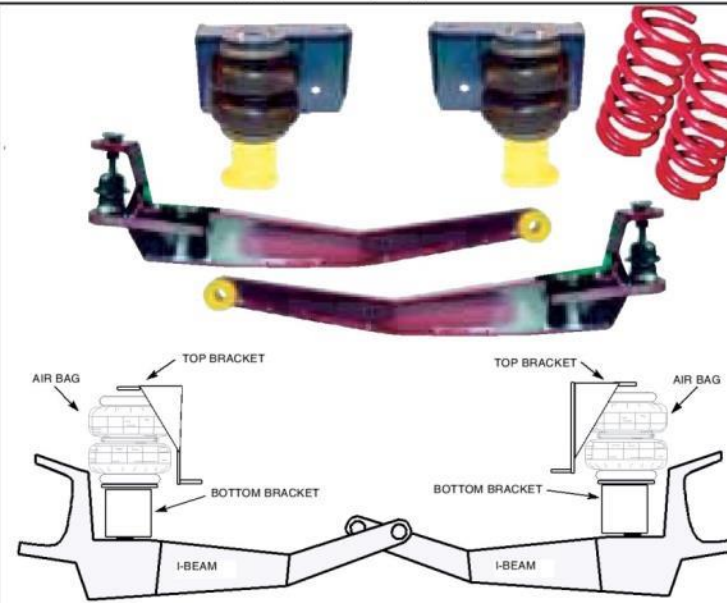





Weld nut to center / top of plate away from bag,
then screw threaded rod into new welded nut.
To finish slide pipe (barrel) over threaded stud and
hold into position in upper coil cup while using washer
and nut to retain assembly through the shock tower.

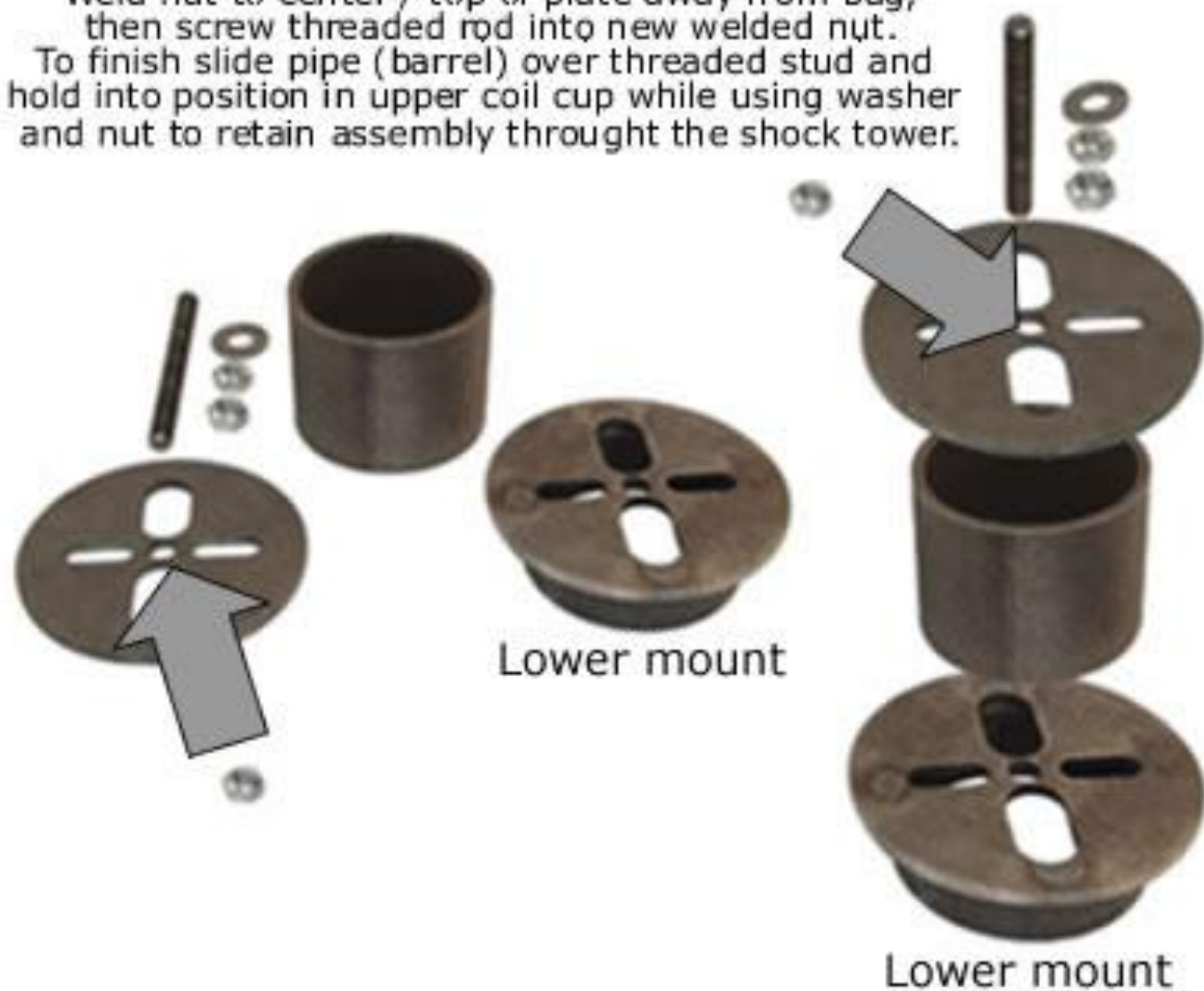



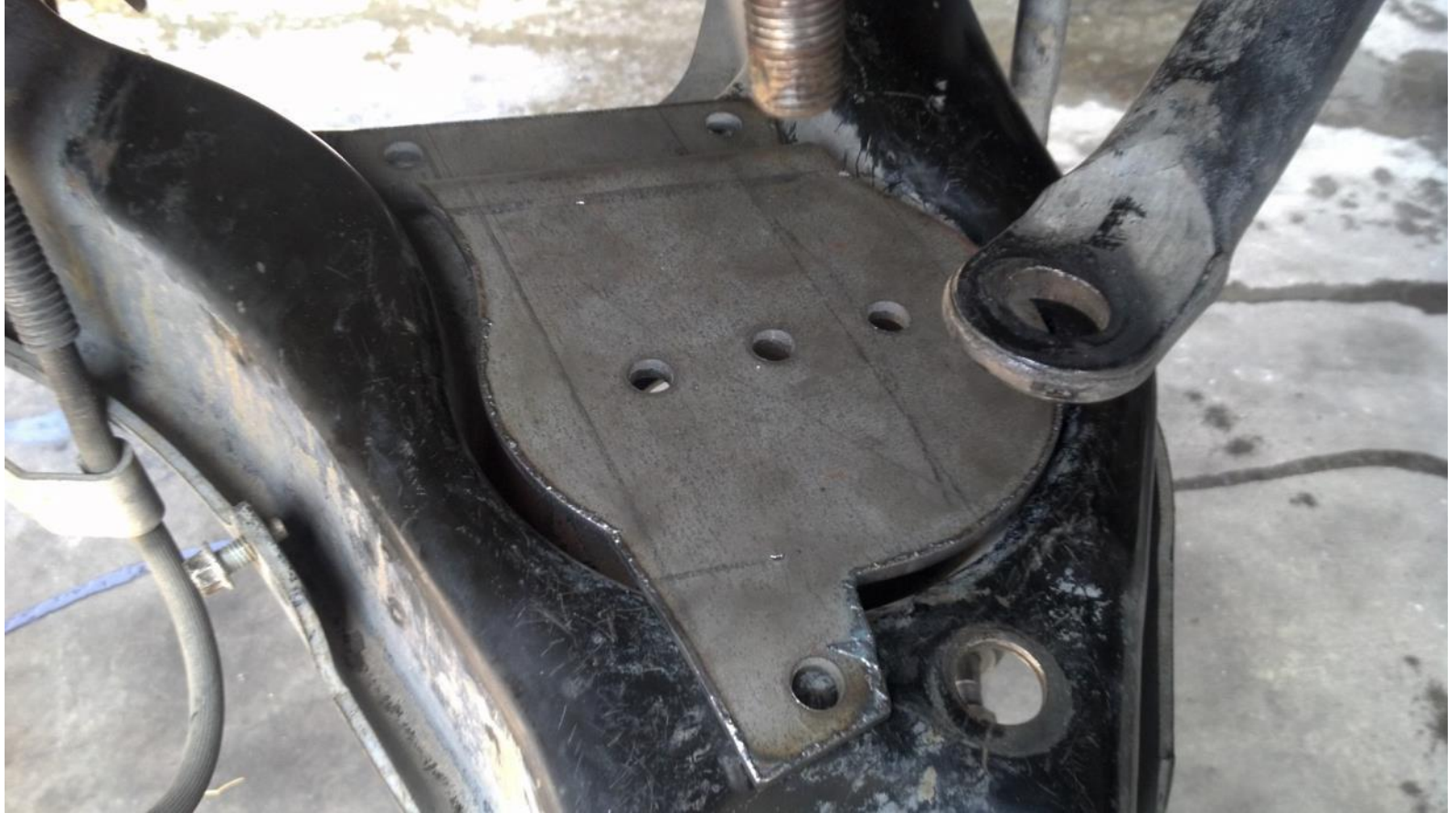



BMW



FIAT STILO



2007 RAM 1500



CHEV COLORADO



2001 CIVIC



NISSAN



PORSCHE CAYENNE



MERCEDES



FORD ESCORT



CHRYSLER 300

Our AIRSTRUTS are Direct Factory Bolton, using the original factory mountings. We have over 1,000 applications

We show only a few examples of our vast inventory above

AIR STRUT INSTALLATION

Note: This is a general guide to installing struts and is not vehicle specific. Your application may differ slightly. For strut removal and installation procedures specific to your application refer to a service manual for your vehicle.

There is no cutting or welding. Simply remove your factory strut, and reinstall, reversing the procedure.

AIR STRUT INSTALLATION

1. **Disconnect the battery**
2. **Raise the car and put on jack stands.**
3. **Remove the wheels.**
4. **Remove the bottom bolts attaching the lower strut mount to the spindle.**
5. **Remove brake line clips, sway bar links, ABS sensors, and anything else attached to the strut.**



6. **Pop open the hood and remove the 3 nuts attaching the strut to the body.**
7. **Remove the strut.**



8. **You will need a spring compressor to compress the spring so you can remove the upper nut attaching the upper strut mount to the strut. Pop off the cap and remove the nut. Make sure your safety goggles are on.**
9. **Remove the strut mount, spring and dust cover.**



5. Install the OEM upper strut mount to the Air Strut with the supplied hardware. Now reinstall the new Air Strut and reverse steps 7 through 4. You will notice that the new air strut has 2 sets of mounting holes. This is an extra 1" of adjustment that can be used for leveling the front and rear with each other, extra room for tire clearance, or just to go lower. Be aware that if the upper set of holes is used, the bottom set of holes may need to be trimmed off for CV boot and axle clearance. Also make sure that the air bag does not come in contact with anything. Sheet metal may need to be bent or trimmed to properly fit the strut.

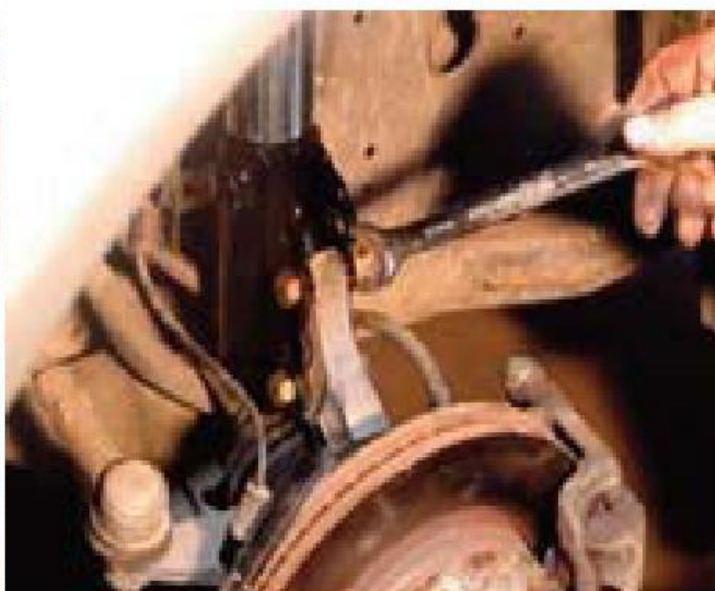

6. With the supplied custom fittings, you will need to use a thread compound or Teflon tape to the Air Strut. Do not over tighten. Be careful. The way these fittings work is by inserting a straight cut piece of tubing into the fitting until it pops into place and then pull out to engage them. If you need to remove them again, simply push the brass rings in and pull out the tubing.
7. Keep your air lines away from sharp edges, moving parts, or hot exhaust
8. Do a leak test on the air lines. Please take your time so you will not have a problem in the future. Use a soapy solution on the fittings and fix if necessary.
9. Reinstall the wheels and remove the jack stands. Make sure the bags are inflated so you can remove the jack safely without damaging the car.

CARTRIDGE STYLE STRUT INSTALLATION:

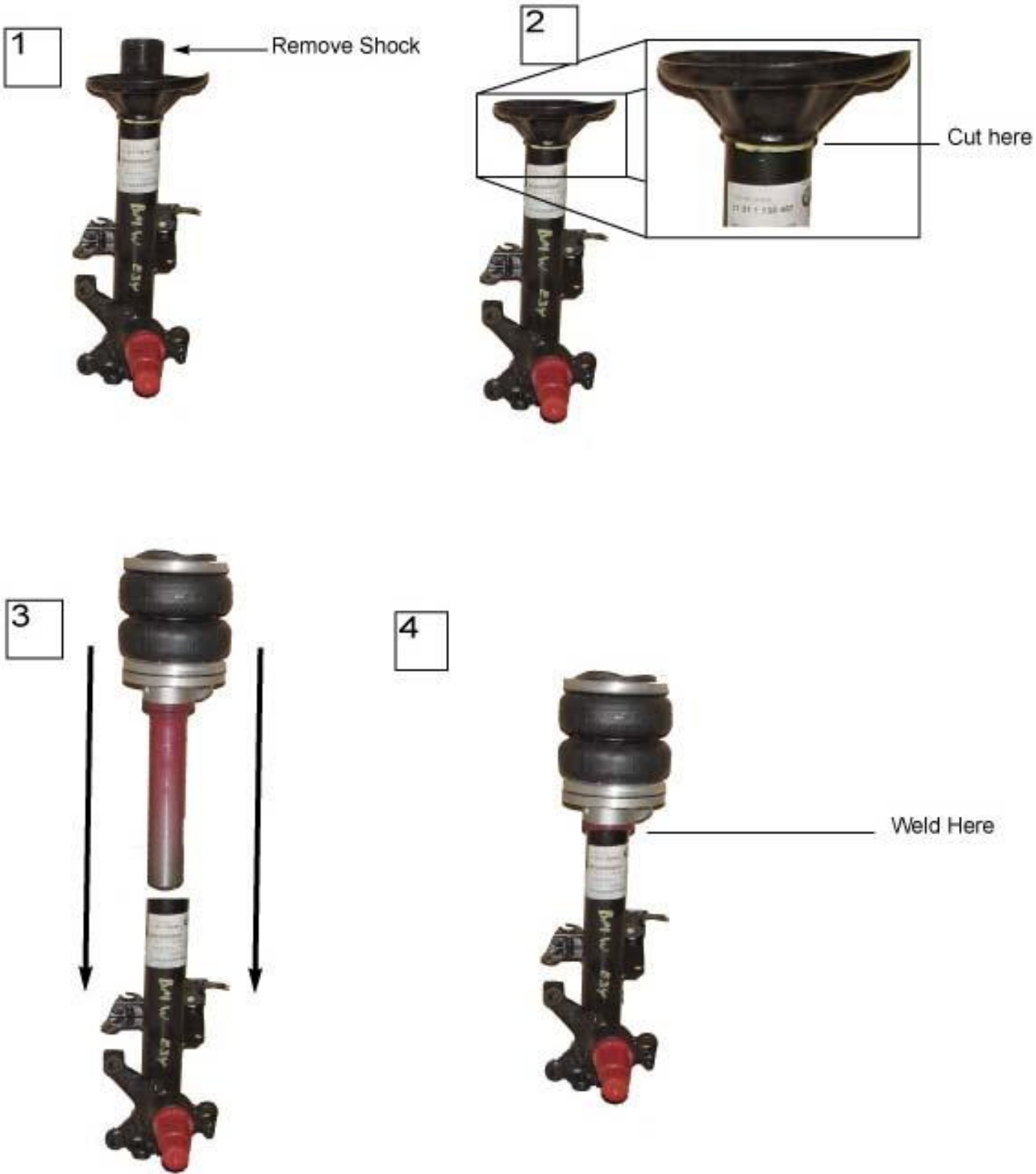

*****THE LOWER SECTION OF THE STRUTS THAT USE THE FACTORY CARTRIDGE IS TRIMMABLE*****









**STILL HAVE QUESTIONS? PLEASE
GIVE US A CALL AT: 1-800-823-0230**

**KNOWLEDGABLE
REPRESENTATIVES ARE WAITING
TO HELP.**

www.X2INDUSTRIES.COM

sales@x2industries.com

inquiry@x2industries.com